

TRIUMPH BONNEVILLE SPEEDMASTER '25-

Cúpula NG Sport-
Windshield NG Sport

REF. 22998



1 Person



20 Min



EASY



ID.	PIEZA / PART	DESCRIPCIÓN	DESCRIPTION	QTY	REF.
1		Cúpula Sport	Sport screen	1	11053F/H/J/N/WM3
2		Soporte derecho (R)	Right support (R)	1	SOPOR2P2-L22999
3		Soporte Izquierdo (L)	Left support (L)	1	SOPOR2P2-R22999
4		Casquillo $\phi 8 \times \phi 13 \times 12 \text{mm}$	$\phi 8 \times \phi 13 \times 12 \text{mm}$ Arrowhead	2	CASQUI-M----769
5		Tornillo Allen M8x45 DIN912	M8x45 DIN912 Allenscrew	2	TORNI-AD912-508
6		Silentblock M5	M5 Silentblock	4	SILENBTM5-046/1
7		Arandela de nylon M5	M5 Nylon washer	4	ARNV00000000245
8		Tornillo Allen M5x16 $\phi 11$ ISO 7380	M5x16 $\phi 11$ ISO 7380 Allenscrew	4	TORNI-I7380-493
9		Tapón tornillo M5 ISO 7380	M5 ISO 7380 screw cap	4	TAPON-----85

TRIUMPH BONNEVILLE SPEEDMASTER '25-

Cúpula NG sport-
Windshield NG sport

REF. 22998

1

DESMONTAJE
DISASSEMBLY

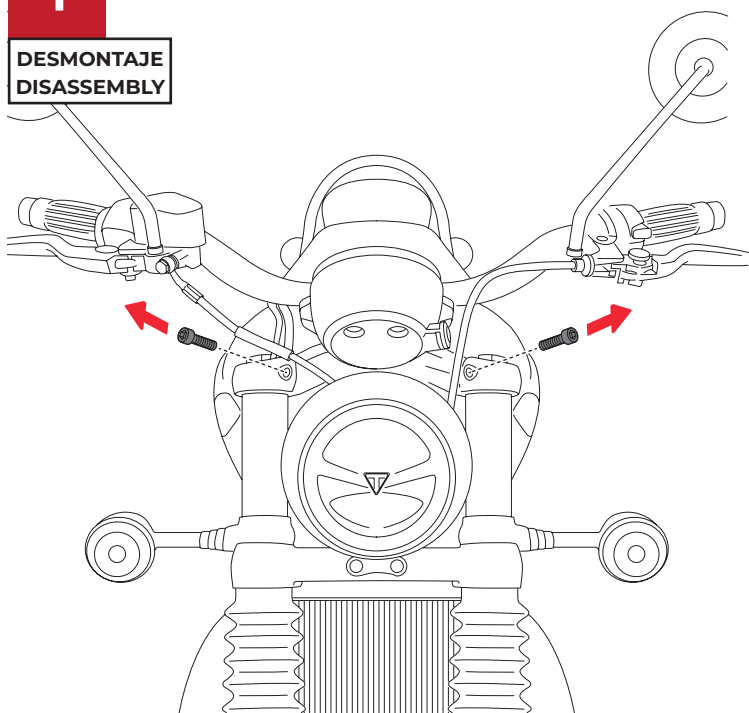

2

DESMONTAJE
DISASSEMBLY

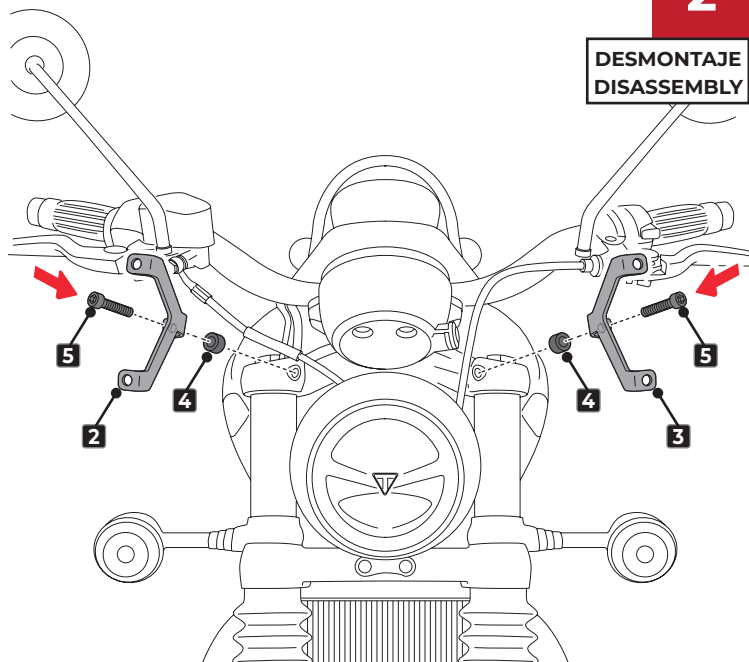

A  Par de apriete - consultar manual del fabricante
Tightening torque - consult the manufacturer's manual

3

MONTAJE
ASSEMBLY

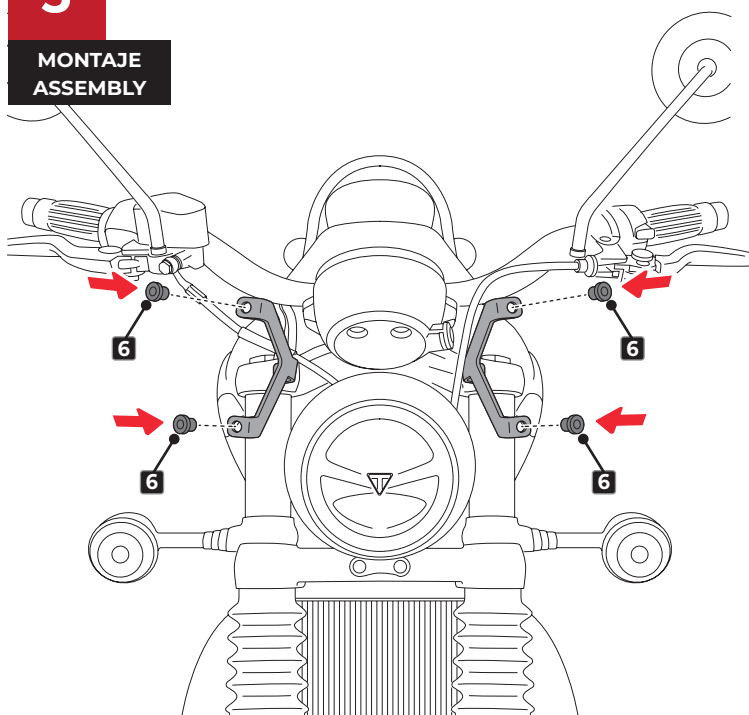

4

MONTAJE
ASSEMBLY

